

7
1

PART: MOTOR MOUNT SIDES
MAT'L: 1/2 AL. PLATE
QTY: 4

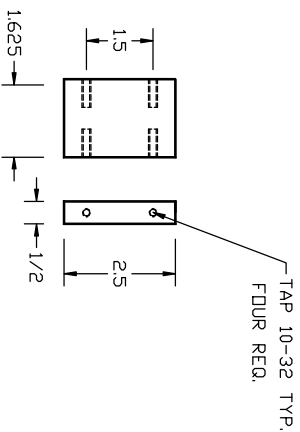

7
3

PART: TOP SPACER
MAT'L: 1/2 AL. PLATE
QTY: 2

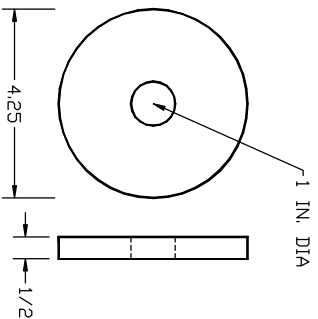

7
4

PART: SHAFT ADAPTER
MAT'L: AL. ROD
QTY: 4

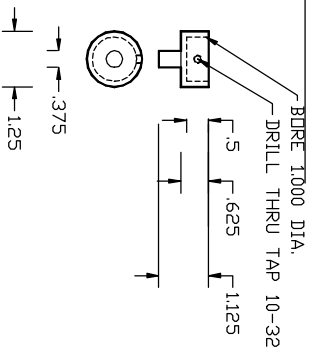

7
2

PART: MOTOR MOUNT SIDES
MAT'L: 1/4 IN. AL. PLATE
QTY: 2

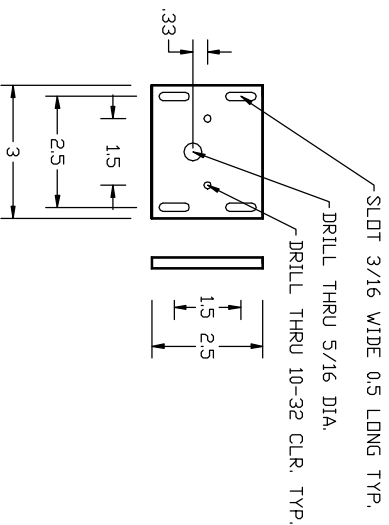

UGASTRO		UNIVERSITY OF CALIFORNIA - BERKELEY	
12GHZ DISH MOUNT			
SMALL PARTS			
DWG BY	R. TREFFERS	DATE	6/27/97
DWG REVISION		SHOWN ON	RTLL001
DWG NO	RTLL007	SCALE	1 : Not To Scale
REV			