

6
1

PART: LEFT YOKE
MAT'L: 1/2 AL. PLATE
QTY: 2

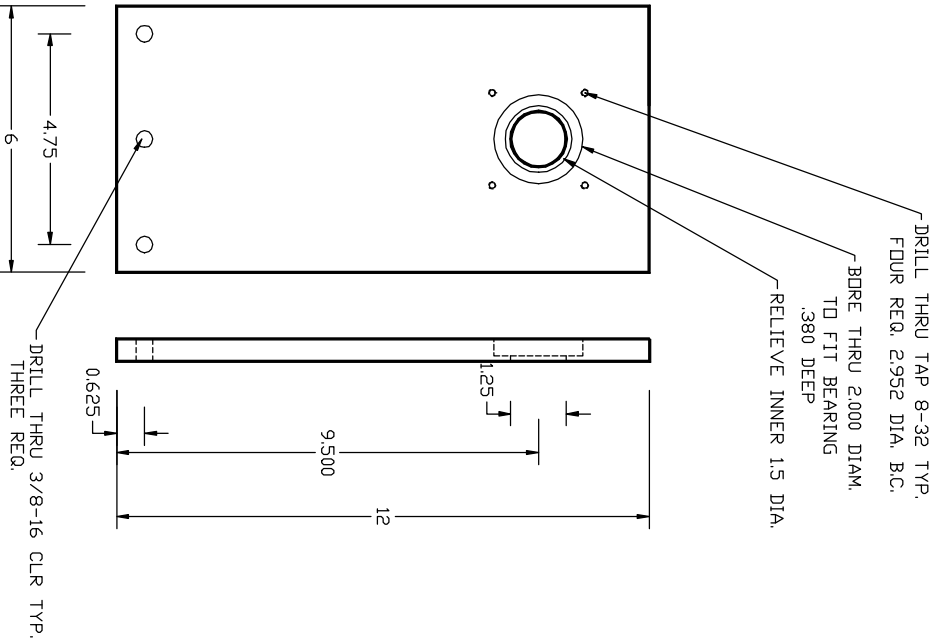

6
2

PART: RIGHT YOKE
MAT'L: 1/2 AL. PLATE
QTY: 2

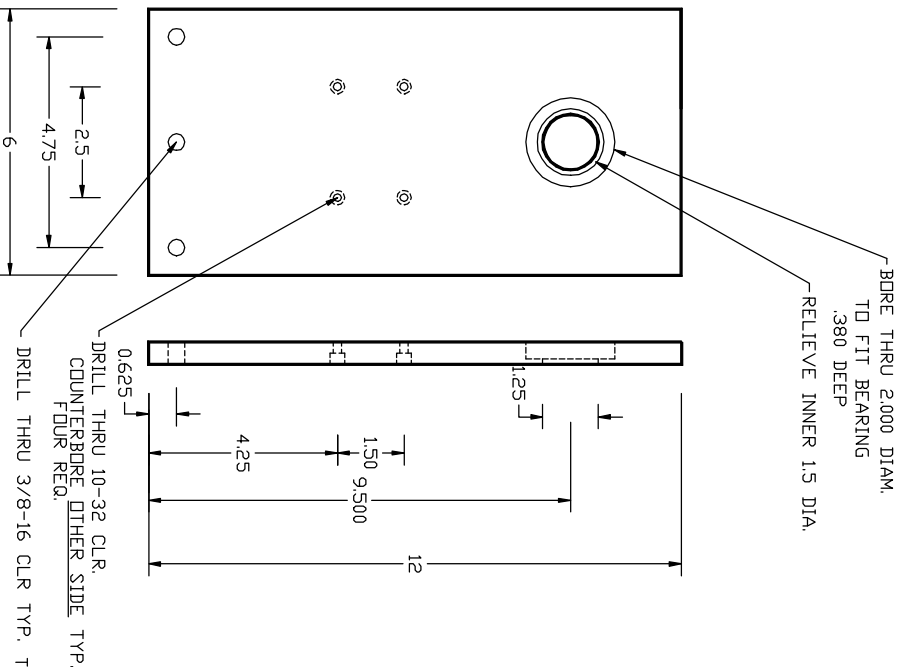

6
3

PART: YOKE BASE
MAT'L: 1.25 IN. AL. PLATE
QTY: 2

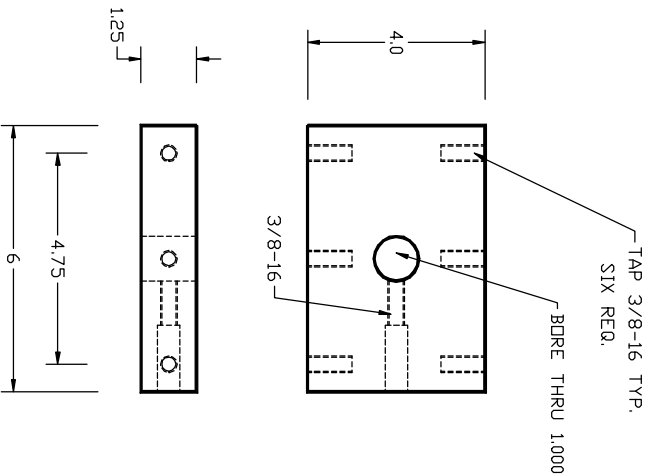

UGASTRO
UNIVERSITY OF CALIFORNIA - BERKELEY

12GHZ DISH MOUNT

YOKE

DWG BY R. TREFFERS	DATE 6/27/97	SHOWN DN RT	SCALE 1: Not To Scale
DESIGN BY		DWG TYPE RT	REV RT