

7/27/2000 INCREASE MIRROR DIA., DECREASE OUTER DIA., CLARIFY DIMS

32 PART: MIRROR HOLDER
 MAT'L: 6061 AL.
 QTY: 1

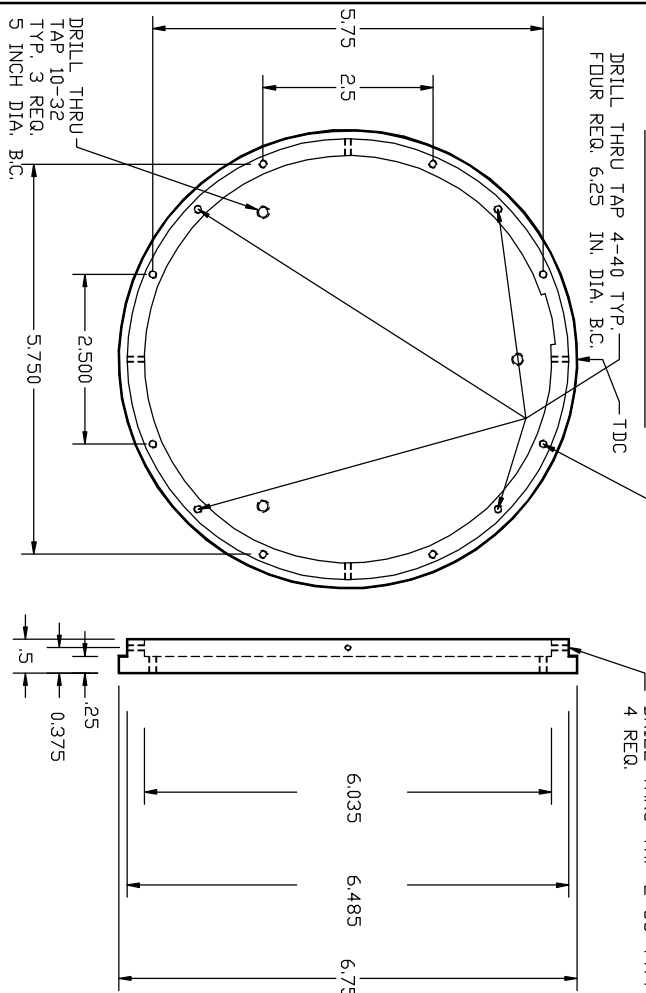

32 PART: MIRROR RETAINER
 MAT'L: 6061 AL.
 QTY: 1

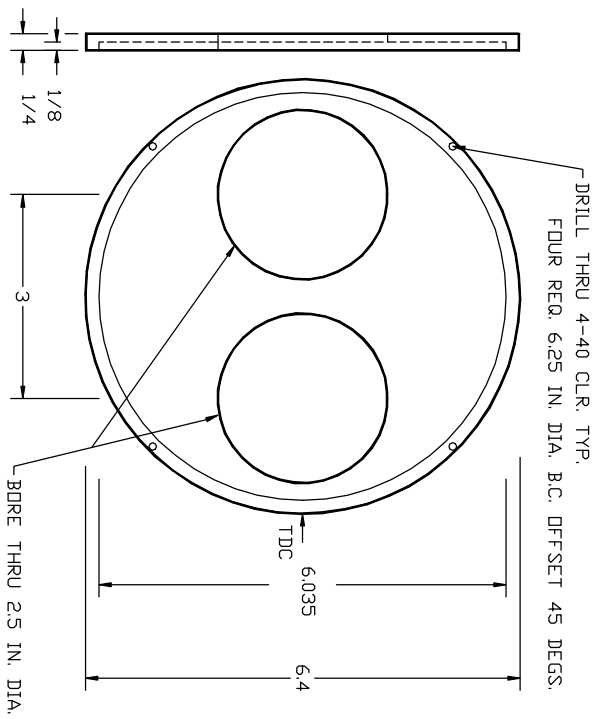

32 PART: SECONDARY RETAINER
 MAT'L: 6061 AL.
 QTY: 1

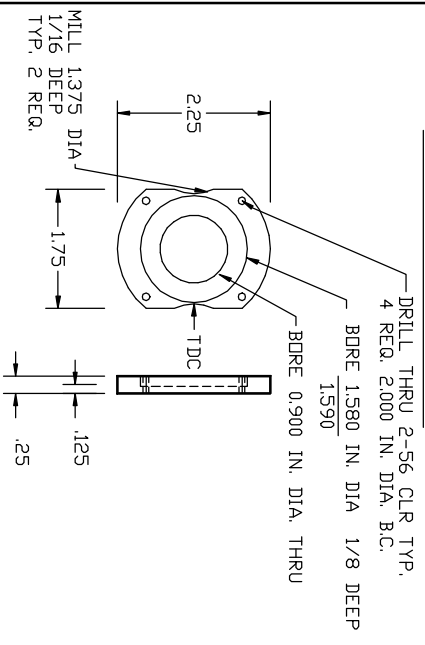

32 PART: BRACKETS
 MAT'L: 6061 AL. 1/4 BAR
 QTY: 8

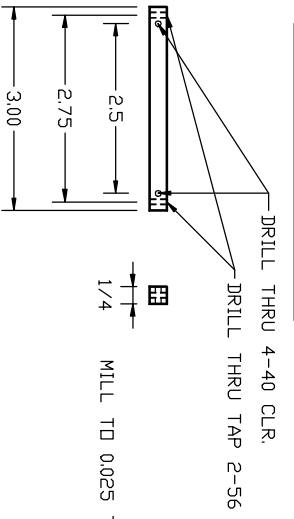

32 PART: SPACERS
 MAT'L: 1/16" GIO FIBERGLASS
 QTY: 4

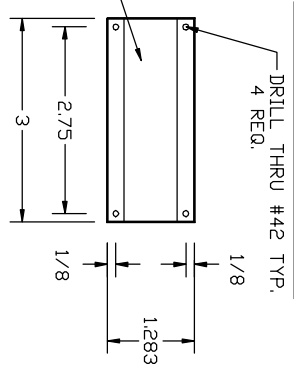

LEUSCHNER OBSERVATORY

UNIVERSITY OF CALIFORNIA - BERKELEY

TR CAMERA			
DEWAR MARK II			
MIRROR MOUNT			
DATE	8/31/2000	SHOWN IN	IRCAM025
BY	R. TREFFERS	TYPE	DETAIL
SCALE	1/8" = 1"	NO. TO SCALE	IRCAM032
REV			