

28
1

PART: FRONT FLANGE
 MAT'L: ALUMINUM NW200 BOLTED FLANGE
 QTY: 1

DRILL THRU TAP M10-1.5 TYP.
 12 REQ. 260 MM DIA. B.C.

7/27/2000 SPECIFY M10 THREAD AND SLOT DEPTH

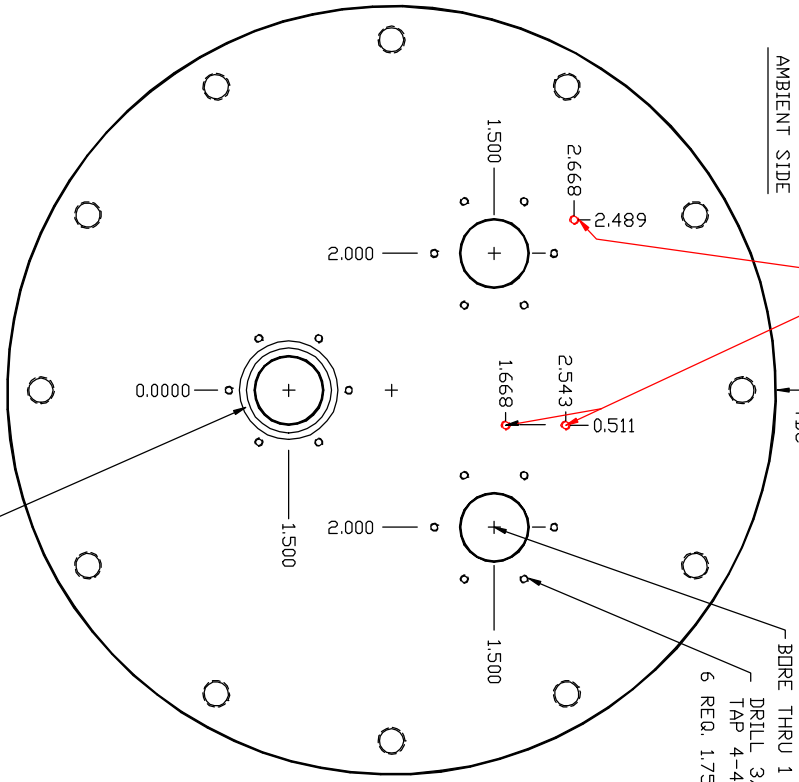
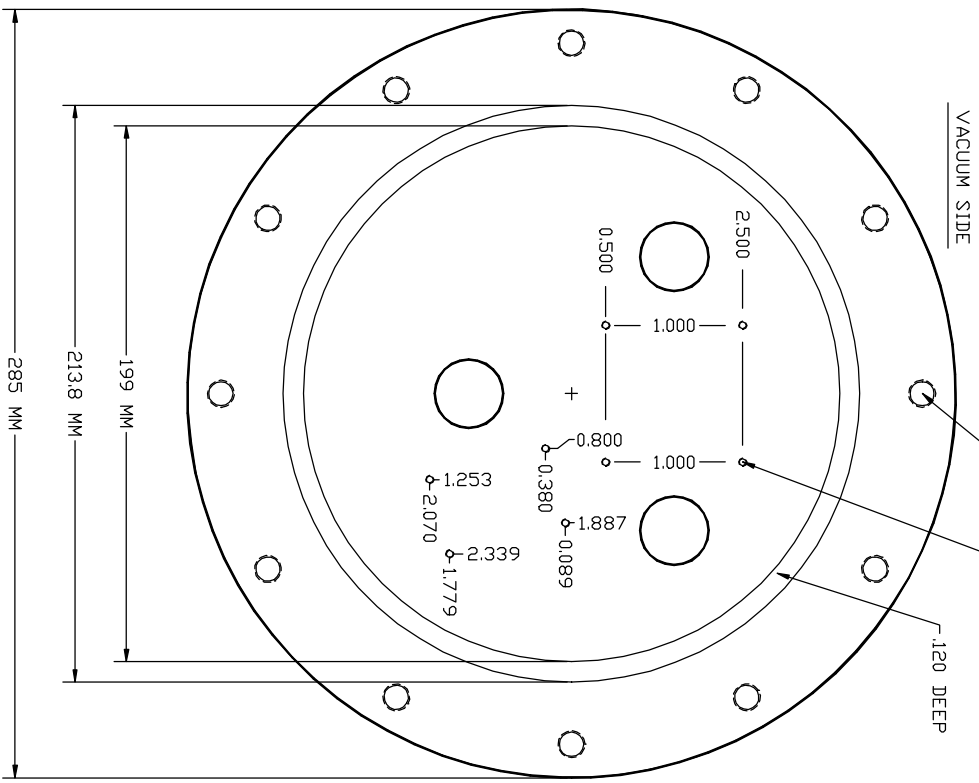

NOTE: ORDINATE DIMENSIONS WITH RESPECT TO CIRCLE CENTER

LEUSCHNER OBSERVATORY			
<small>UNIVERSITY OF CALIFORNIA - BERKELEY</small>			
IR CAMERA			
DEVAR MARK II			
FRONT FLANGE			
DATE	BY	SHOWN IN	SCALE
8/10/2000	R. TREFFERS	IRCAM028	1:1
SECTION	TYPE	NO.	REV.
	DETAIL	1	IRCAM028