

8
1

PART: SHIELD BOTTOM
MAT'L: ZERD CAN
QTY: 1

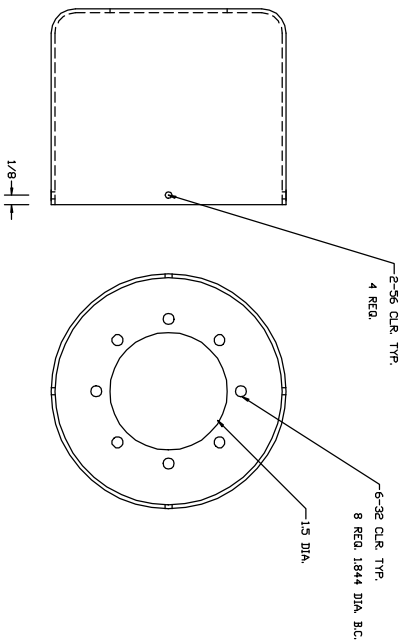

8
2

PART: SHIELD TOP
MAT'L: ZERD CAN
QTY: 1

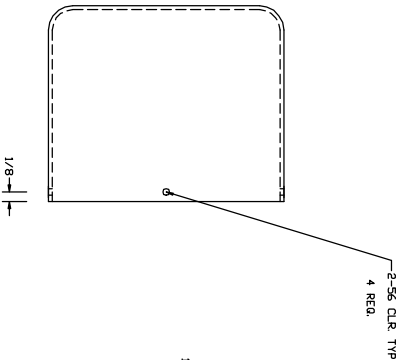

8
3

PART: JOINING RING
MAT'L: AL
QTY: 1

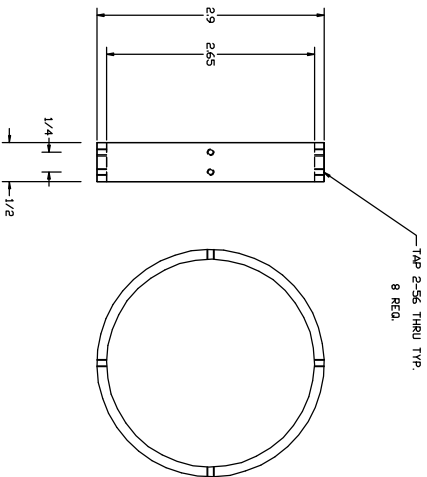

8
4

PART: T. SENSOR HOLDER
MAT'L: AL
QTY: 1

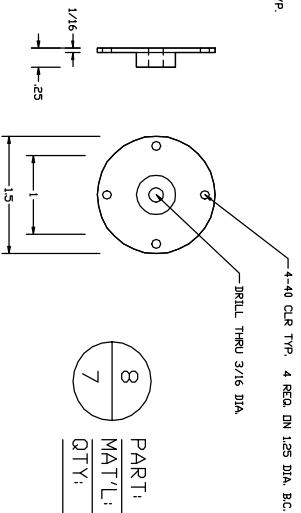

8
7

PART: WASHERS
MAT'L: 1/16" AL.
QTY: 5

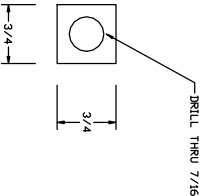

8
5

PART: BOTTOM STRAP
MAT'L: COPPER
QTY: 1

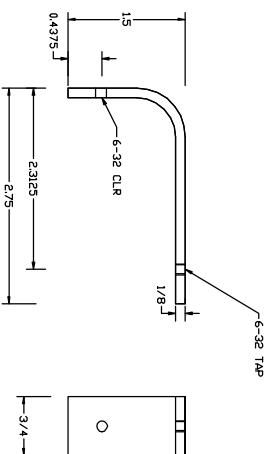

8
6

PART: TOP STRAP
MAT'L: 1/16 COPPER
QTY: 1

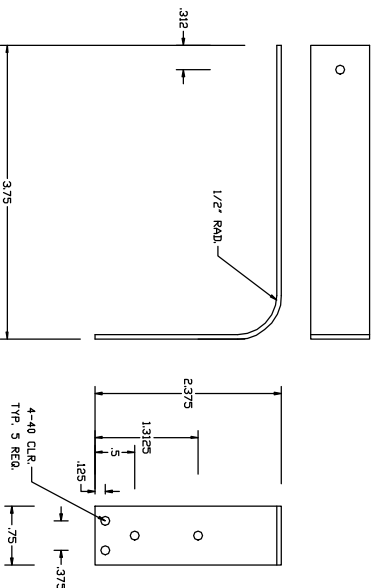

LEUSCHNER OBSERVATORY			
UNIVERSITY OF CALIFORNIA - BERKELEY			
IR CAMERA			
DEWAR			
RADIATION SHIELD			
DATE	2/25/99	SHOWN	IRCAM002
BY	R. TREFFERS	DWG	
REVISION		DATE	
		SCALE	1 NOT TO SCALE
		DWG	IRCAM008
		REV	