

5
1

PART: FRONT PLATE
 MAT'L: 3/8 ALUMINUM
 QTY: 1

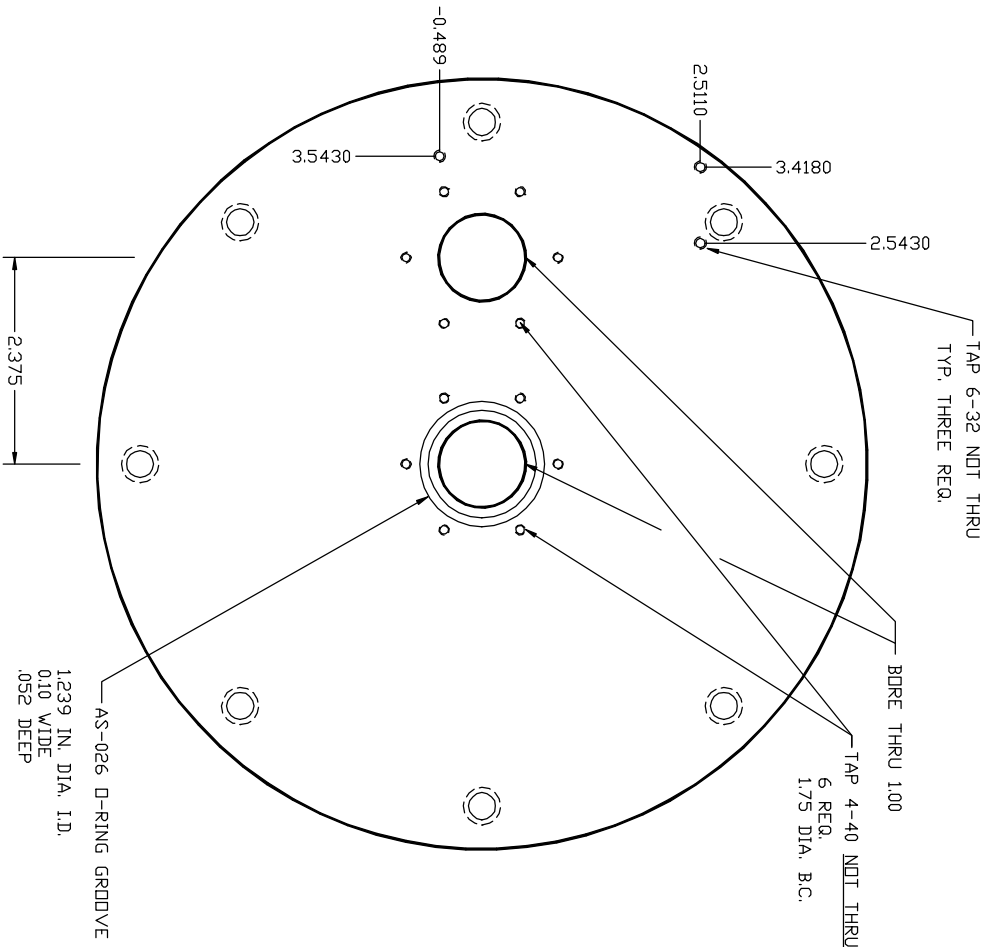
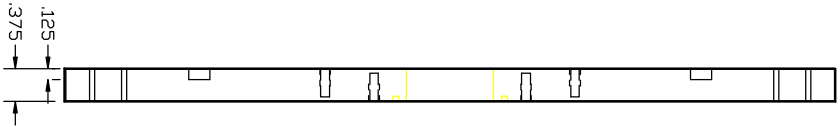
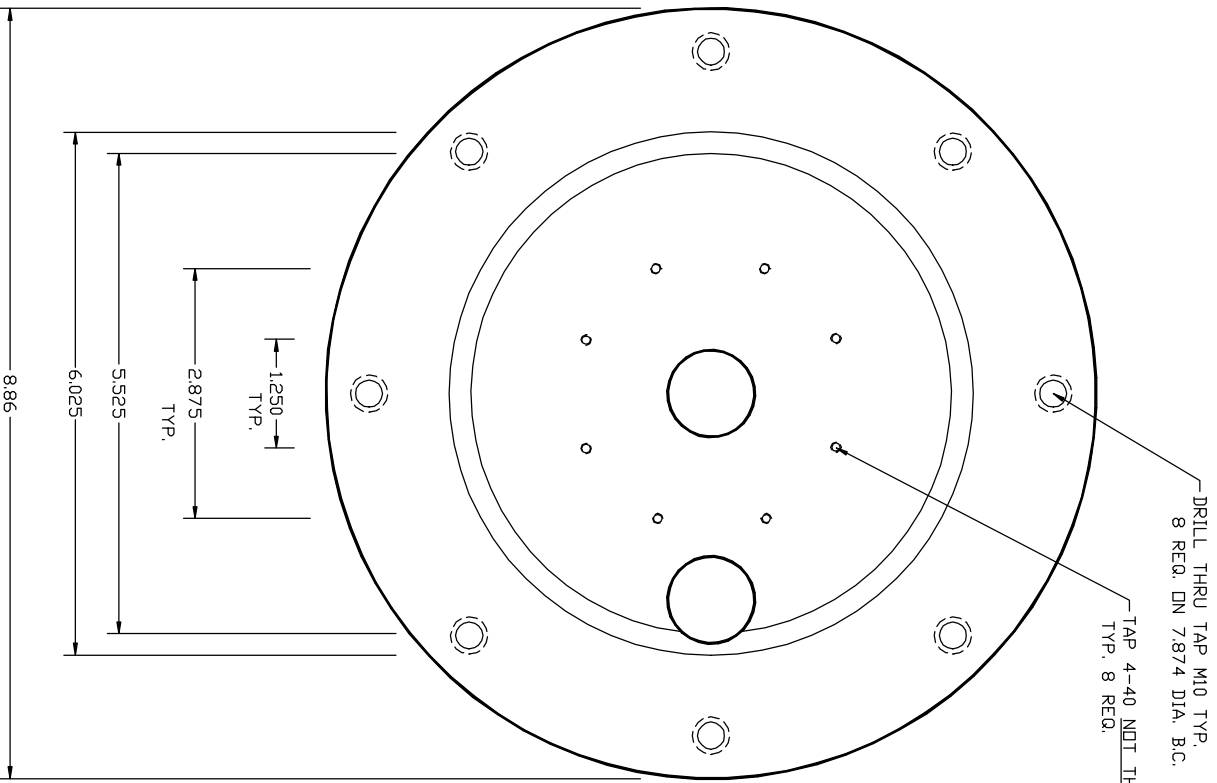

LEUSCHNER OBSERVATORY			
UNIVERSITY OF CALIFORNIA - BERKELEY			
IR CAMERA			
DEWAR			
FRONT PLATE - WINDOW SIDE			
DESIGN	DATE	SHOWN	SCALE
BY R. TREFFERS	7/8/98	DN	1:1 Not to Scale
SECTION		DWG TYPE	REV
		IRCAM002	No
		IRCAM005	