

16  
1

PART: BEARING SHAFT  
 MAT'L: 1/2 DIA. S.S. ROD  
 QTY: ONE

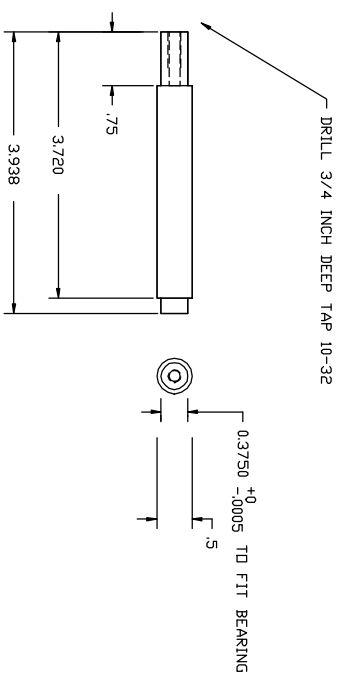

16  
2

PART: MIRROR HOLDERS  
 MAT'L: 3/4 ALUMINUM  
 QTY: TWO REQUIRED

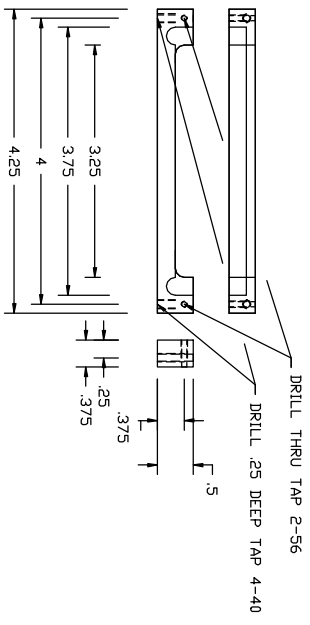

16  
3

PART: LENS RETAINER  
 MAT'L: ALUMINUM  
 QTY: ONE

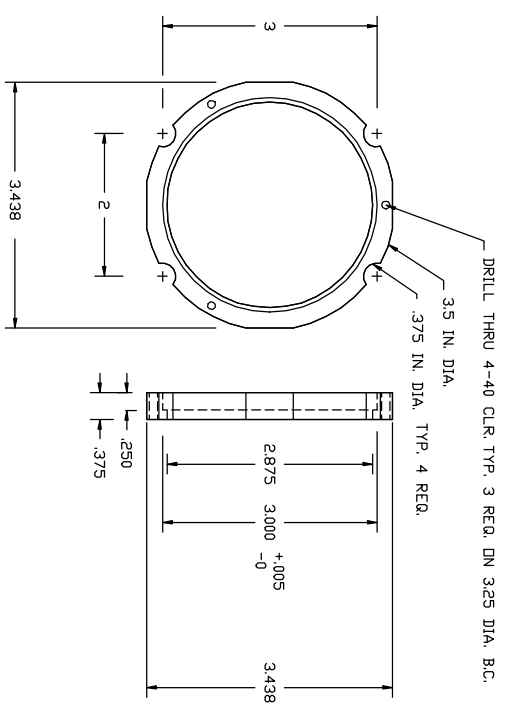

16  
4

PART: MIRROR CLIPS  
 MAT'L: PHOSPHOR BRONZE  
 QTY: FOUR REQUIRED

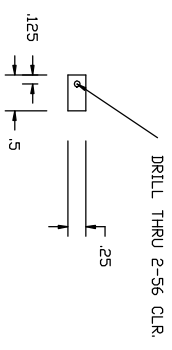

16  
5

PART: SPACER  
 MAT'L: BRASS  
 QTY: ONE REQUIRED

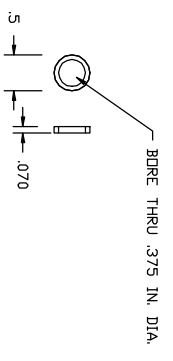

<b>LEUSCHNER OBSERVATORY</b> UNIVERSITY OF CALIFORNIA - BERKELEY			
BERKELEY AUTOMATED IMAGING TELESCOPE CAMERA AND GUIDER			
<b>SMALL PARTS</b>			
DATE	BY	SCALE	REV
3/20/91	R. TREFFERS	37M001	D
			SCALE: NOT TO SCALE
			REV: 37M016
			A