

11
1
PART: MOUNTING FLANGE
MAT'L: 1/4 INCH ALUMINUM
QTY: 1 REQ.

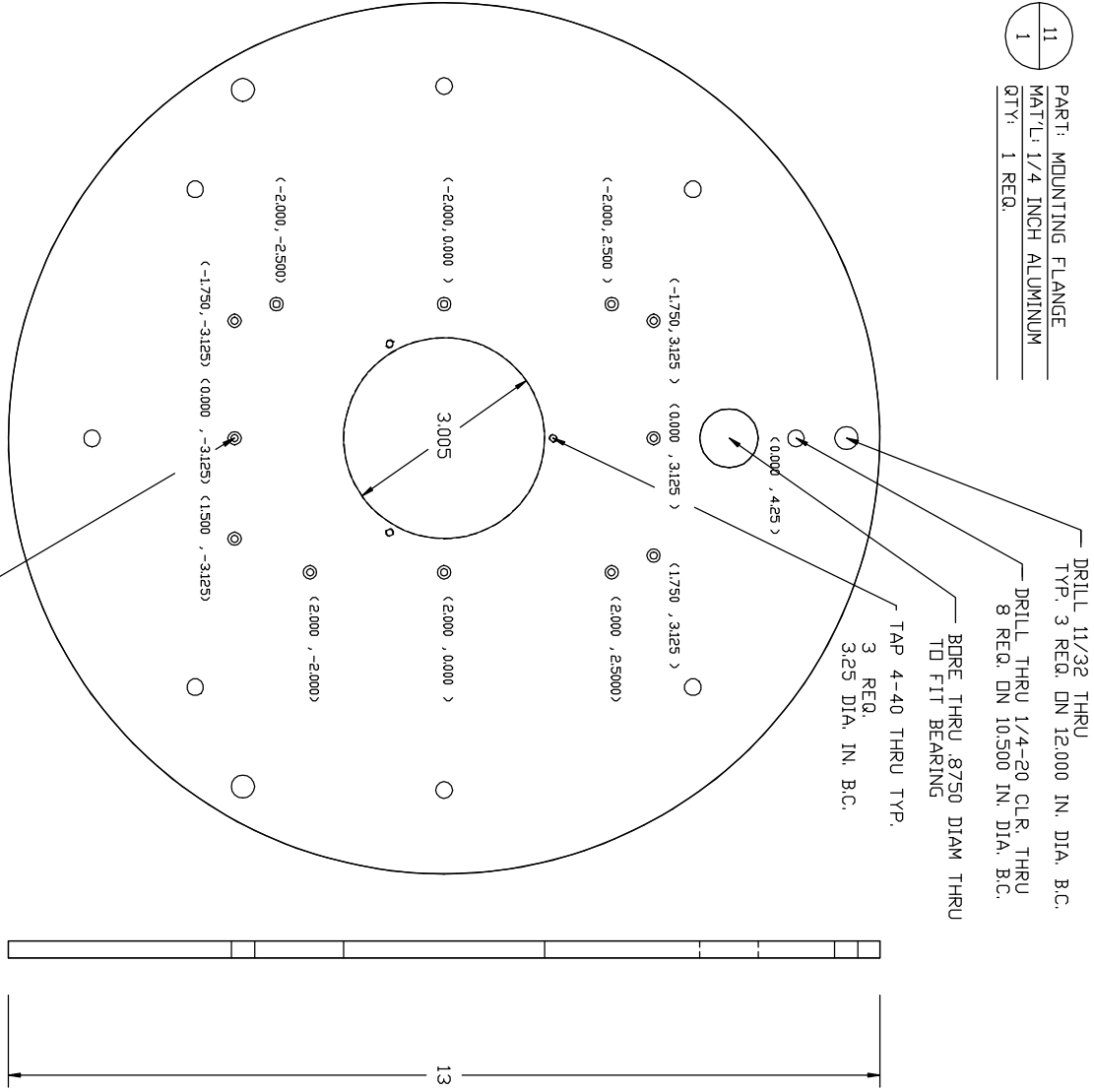

NOTE:
1. (X,Y) OFFSETS FROM CENTER
DRILL THRU 4-40 CLR. CNTB
TYP. 12 REQ.

11
2
PART: LOCATING RING
MAT'L: .5 INCH ALUMINUM
QTY: ONE REQ.

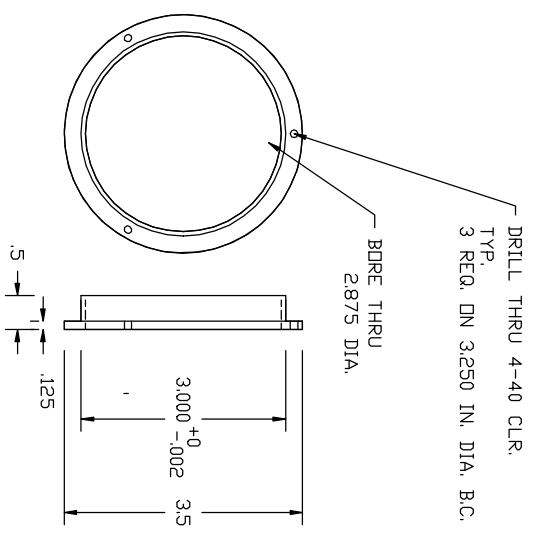

LEUSCHNER OBSERVATORY			
UNIVERSITY OF CALIFORNIA - BERKELEY			
BERKELEY AUTOMATED IMAGING TELESCOPE			
CAMERA AND GUIDER			
MOUNTING FLANGE			
BY R. TREFFERS	DATE 3/15/91	SHOWN ON 37M001	SCALE: NOT TO SCALE
DESIGN		TYPE D	REV 37M011